

HYDRAULIC BEHAVIOUR OF THE FLOATING WAVE ENERGY CONVERTER WAVE DRAGON

T. Hald^{*1}, E. Friis-Madsen², J.P. Kofoed¹

¹ Hydraulics & Coastal Engineering Laboratory, Department of Civil Engineering,
Aalborg University, Sohngaardsholmsvej 57, DK-9000 Aalborg, Denmark

² Löwenmark Consulting Engineers F.R.I., Blegdamsvej 4, DK-2200 Copenhagen N, Denmark

*: Corresponding author's email: txh@ramboll.dk

ABSTRACT

One of the main types of wave energy converters is the overtopping devices, that collect the water of incident waves to drive low head turbines. The Wave Dragon is a device of this type and has been under continuous development since 1995 through national as well as international wave energy programmes. In 1999/2001 the Wave Dragon has been patented national and in Europe.

The present paper describes the principle of the Wave Dragon and summarizes the various developments done to the Wave Dragon design ending up in a reconstruction termed the 2. generation Wave Dragon model. The hydraulic behavior of this 2. generation model is evaluated by physical model tests and conclusions from these tests are presented and discussed. Finally, conclusions and the future developments plans are presented.

INTRODUCTION

Over the recent years wave energy converters (WECs) have gradually been brought into focus utilising various concepts of energy conversion from the waves. One special class of WECs is the overtopping type, i.e. a converter that utilise the potential energy obtained, when waves are overtopping into a reservoir at a higher level than MWL by leading the water back into the sea through a number of turbines. Among such WECs is the Wave Dragon (WD), developed and patented by Friis-Madsen (1999, 2001). The WD has been under continuous development since 1995 supported by the European Union (EU) through the JOULE-CRAFT programme and the Danish Wave Energy programme.

The main objective of the present paper is to describe the current state of the WD development including improvements and modifications made to the 1. generation WD presented in Kofoed et al. (2000) and Sørensen et al. (2000) during the JOULE-CRAFT programme and the Danish Wave Energy programme. The modified 2. generation WD is tested in a physical model in order to investigate the hydraulic performance and verify expected results of the modifications. Results from these model tests are presented in the paper.

PRINCIPLE OF THE WAVE DRAGON

The WD is a slack-moored offshore wave energy converter to be deployed in parks at more than 20 m water depth, which generally in the North Sea is more than 25 km offshore. Each unit is envisaged to be installed with 4 MW generators. WD consists of three main elements:

- Two patented wave reflectors for focusing the waves towards the overtopping ramp.
- The main body consisting of a patented doubly curved ramp and a reservoir.
- A set of low head Kaplan-propeller turbines for converting the hydraulic head in the reservoir into electricity.

In full scale the pressure height over the turbines will vary between 1 and 4 meters. The WD is designed to be floating on open chambers of pressurised air in order to damp the movements as well as allowing adjustments of the free board by varying the air pressure in the chambers.

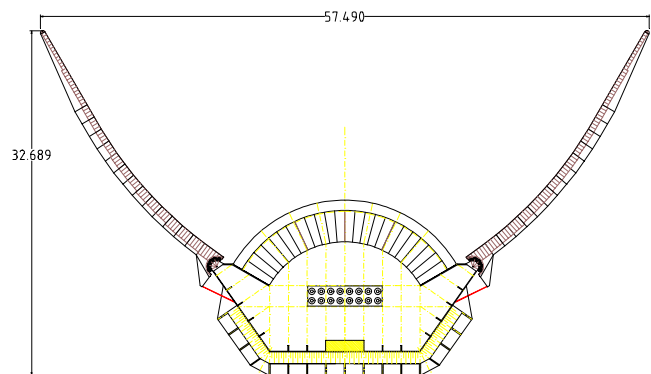

Figure 1: Plan view of the Wave Dragon scale 1:4.5.

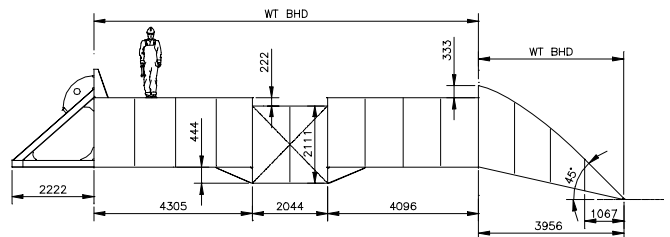

Figure 2: Cross sectional view of the reservoir part of the Wave Dragon scale 1:4.5.

Data on the planned scale 1:4.5 Wave Dragon model:

Width between the wave reflectors:	57 m
Wave reflector length:	28 m
Ramp crest width:	27 m
Reservoir size:	55 m ³
Weight: 163 tons steel + 74 tons ballast =	237 tons
Rated power	20 kW
Turbine hydraulic efficiency at 0.7 m head	87 %

Data on full-scale prototype:

Width between the wave reflectors:	260 m
Wave reflector length:	125 m
Ramp crest width:	120 m
Reservoir size:	5,000 m ³
Weight: 21,400 tons concrete + 350 tons steel =	21,750 tons
Rated power (16 variable speed axial turbines)	4,000 kW
Turbine hydraulic efficiency at 3.0 m head	91%

HISTORY OF THE WAVE DRAGON DEVELOPMENT

Phases year	Activity
Phase 1 1987-1996	Formulation of the idea/concept, energy and economic considerations, patent application. Financial support from EFS to establishment of international co-operation. Two BSc thesis ECC
Phase 2 1997	Testing of a simple model scale 1:45 in a wave tank to establish basic data on reflectors, ramp and energy efficiency. MSc thesis AAU
1997-1998	Establishment of a Joule Craft project (phase 3a) and Research Feasibility Study
Phase 2a 1998	Establishing of a model scale 1:50 at DMI Testing in a wave tank at AAU to establish the response from waves of different height, the magnitude of the forces in the mooring system and the energy efficiency.
Phase 2b 1999	Adjustment of the model and the design parameters with reference to phase 3
Phase 3a 1998-2000 1998-1999	Further testing of a model scale 1:50 to establish the design parameters of important parts (flow in the turbines, strategy for choice of turbines). Optimising of the power unit (turbines, cable connections, transformation, generators). Optimisation of turbines and reservoir. BSc thesis, ECC. MSc thesis AAU
Phase 3b 2000	Development and tests of an axial turbine with variable speed and 2 different inlet types and 2 different runner-wheels
Phase 3c 2000-2001	Sequential modifications and testing of the existing 1. generation scale 1:50 model. The test will show the influence on Wave Dragon 's performance by changes in different geometry- and mass distribution parameters. The test series will establish improved design parameters for a scale 1:4.5 prototype Ph.D. thesis at AAU on ramp design.
Phase 4a 2002-2004	Design of a scale 1:4.5 prototype and deployment in a small Danish inlet (Nissum Bredning) with wave conditions resembling a downscaled North Sea climate.

At the end of phase 3 the Wave Dragon development costs have passed 2 mill. €. The budget for phase 4a is approximately 1.7 mill. €.

The Wave Dragon has been subject to thorough testing in scale 1:50 carried out in wave tanks at Aalborg University and University College Cork, and a highly efficient power take-off in the form of an axial turbine in scale 1:3.5 has been developed. The turbine has been tested in the acknowledged turbine test stand at Technical University Munich, see Figure 3-4. Furthermore a significant development and design optimisation program has been carried out in a fruitful cooperation among a number of European companies.

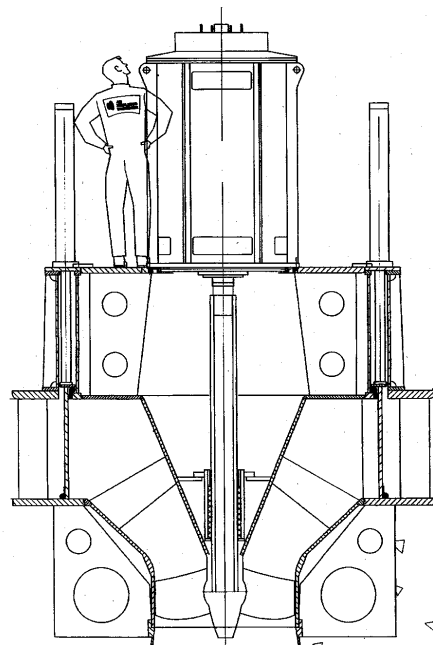

Figures 3 and 4: The Wave Dragon on/off turbine in full scale with cylinder gate and the existing test turbine in scale 1:3,5 at the test stand at Technical University Munich.

Because of the size of the reservoir, the Wave Dragon has a - for wave energy converters - unusually large energy storage capacity. Nevertheless the energy storage capacity is not sufficient to prevent variations in the pressure height in relation to the energy periods of the waves. Hydro turbines in regular hydro power plants are not subject to such rapid pressure variations over the turbines.

Simulations of the operation of the Wave Dragon has furthermore concluded that start-stop regulation of some of the turbines with a frequency of app. 1 time per minute will be called for in order to optimise the total energy efficiency of the plant. The simulation results have also verified that a more smooth power production is achieved when the turbines are operated at variable speed in correspondence to the actual average pressure height.

In a storm situation the averaged pressure height for the turbines will be subject to changes of up to 1 meter in one hour. The control equipment for the Wave Dragon is therefore very different from the control equipment applied on conventional hydro power plants. An example of a simulation run giving the power production for a given wave situation and a given control strategy is given in Figure 5.

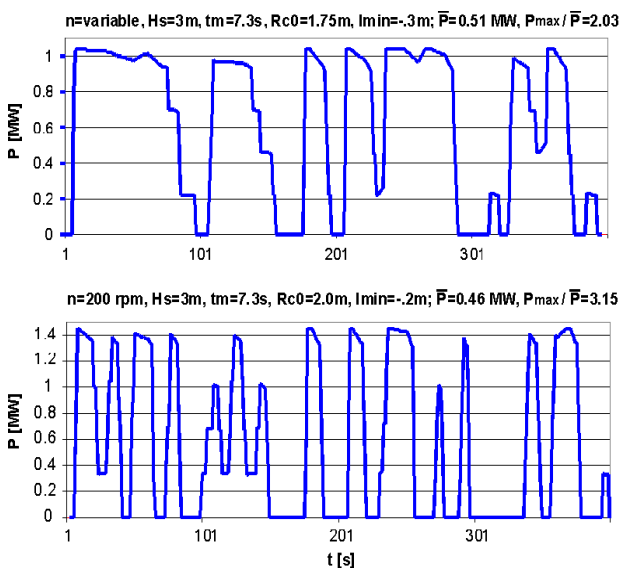

Figure 5: Power production for a 4-step control strategy with fixed and variable speed turbines, for $H_s = 3$ m.

As it can be seen from Figure 5 above, the power production is significantly smoother for variable speed operation of the turbines, which is caused by the fact that the flow through a variable speed turbine decreases significantly more when the pressure height decreases, than what is the case for fixed speed turbines.

The ramp crest freeboard is adjusted in accordance with the prevailing sea state, in order to collect the maximal amount of energy in the reservoir. As said above, the maximum speed of this regulation is 1 meter per hour. The flotation level is adjusted through changing the air pressure in the ballast tanks, which are open towards the sea below. The plant is in this manner to a significant extent carried by the air pressure under the reservoir, which is the main reason why there are significant

non quantifiable scaling effects associated with model tests in small scale. The air pressure in the ballast tanks should, in order to obtain the correct stiffness, be scaled down according to the model scale. This would obviously have made the model sink immediately.

The open-bottomed design of the Wave Dragon has not only been chosen because it diminishes construction material costs, but primarily because pitch movements are significantly diminished compared to a platform with solid bottom.

The Wave Dragon hydraulic behaviour is, however, also significantly influenced by the amount of water in the reservoir, as the weight hereof is up to 35% of the dry self weight of the plant. The ramp freeboard height is therefore significantly influenced by the water level in the reservoir.

Velocity probe. File: 60air40j04js1_26.txt (3m Hs)
Average: 23.6 cm/s

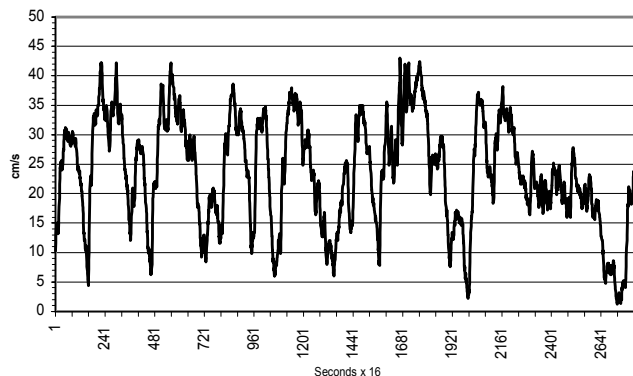

Figure 6: Measured outlet speed in 3 m H_s waves.

In the performed wave tank tests it has not been possible to control the outlet from the reservoir in resemblance with turbine operation. In the overtopping measurements from the tests performed in Aalborg only the total overtopping volume from a significant number of waves were measured. In tests with the 1. generation model performed at University College Cork a rapidly reacting flow meter placed in a central outlet tube were used to measure the outlet from the reservoir. During the tests the outlet area from the reservoir were so large that only a limited amount of water was stored in the reservoir. The results from the Cork tests indicate that the significant variations in overtopping occurring in the simulation results appear to be significantly smaller as can be seen from Figure 6.

The effect of the wave reflectors has been calculated and verified by laboratory experiments at Aalborg University. The wave energy is effectively focused and increased to 140% by the wave reflectors. This result has been found by calculating and measuring the wave field passing straight lines between the reflectors front ends and between the inner ends, without the reservoir part of the Wave Dragon present (Kramer and Frigaard (2002). The 40% increase is valid when the wave reflectors are deployed in a wave climate as found in the Danish part of the North Sea (Table I). In short 1m H_s waves ($T_p = 5.6$ sec) it was found, that the reflectors can produce up to approximately 85% more energy in the cross section.

It is even to be expected that the gain in average power production of the Wave Dragon due to the wave reflectors is somewhat larger than 40%. This is a result of the curved ramp of the reservoir part collecting reflected waves that would not pass the straight line between the inner ends of the reflectors. The efficiency in the power converting process also benefits from the increased wave height in front of the ramp, as this leads to higher heads for the turbines.

The previous Wave Dragon development has been supported by the Danish Energy Agency, the Danish Public Service Program and the European Commission's EU-JOULE-CRAFT programme in the project "Low-pressure Hydro Turbines and Control Equipment for Wave Energy Converters (Wave Dragon)", which were finalised by the end of 2000. Most test reports from the various projects are publicly available. Based on the results from the JOULE project, the design of the Wave Dragon has been modified, and the revised design has been tested in scale 1:50 at Aalborg University. These new tests are described in the following and the effect of the modifications are discussed.

HYDRAULIC PERFORMANCE OF THE 2. GENERATION WAVE DRAGON

In order to investigate the effect of the structural changes to the 1. generation a series of physical model tests have been conducted. The objective of the model tests is to document the hydraulic performance of the 2. generation WD compared to the 1. generation. A scale model of the 2. generation model was reconstructed from an existing 1:50 scale model of the 1. generation WD.

Tests were run for a different number of wave conditions reflecting the North Sea conditions. According wave data are shown in Table I. Wave situations 1 through 5 correspond to normal operating conditions in the North Sea while situation 6 and 7 are extreme wave conditions corresponding to a 50 years and 100 years return period in the North Sea, respectively. The first five wave height represent a power potential of approximately 12 kW/m pr. year compared to 16 kW/m pr. when including wave heights above 5 m.

The duration of each run was 30 minutes corresponding to approximately 4 hours in prototype and each 30 minute wave run was generated to match a JONSWAP spectrum with $\gamma = 3.3$. Accordingly the number of waves ranged from 1400 to 2500 depending on the wave period. Water depth was kept constant at 25 m, which is fairly shallow for a North Sea location but fits the Nissum Bredning conditions when scaled 1:4.5.

Table I: Wave data in the Danish part of the North Sea and related crest freeboard.

Wave ID	R_c [m]	H_s [m]	T_p [s]	Probability [% time]	Percentage of total energy [%]
		0		11	
NS 1	1.25	1.0	6.0	38	6.29
NS 2	2.0	2.0	7.7	27	22.90
NS 3	3.0	3.0	8.8	14	30.47
NS 4	4.0	4.0	9.7	6	25.76
NS 5	4.0	5.0	10.6	2	14.48
NS 6	-	9.0	13.4	0.00091	-
NS 7	-	10.0	14.1	0.00046	-
NS 8	-	12.0	15.0	≈ 0	-

R_c = crest free board relative to MWL

H_s = significant wave height

T_p = peak period

In Table I the crest freeboard relative to MWL, i.e. the position of the WD is also shown for each individual wave situation. When waves encounter the WD it is on one side of major importance to maximise the amount of overtopping water but on the other side it is equally important to maximise the available hydraulic head. Thus, the potential energy determined as the product of amount of overtopping water times the hydraulic head must be maximised. The crest free board in Table I reflect reasonable positions for high energy storage and accordingly the WD must be elevated or submerged to fit the wave conditions best possible. More details can be found in Hald and Friis.Madsen (2001).

In Figure 7 and 8 photos of the WD model are shown. Figure 7 shows the reservoir behind the overtopping ramp as well as the turbine pit where three water outlets can be seen. Figure 8 show the reservoir part from below and the separation into 7 individual open air chambers: one below the overtopping

ramp, three chambers in front of the turbine pit and three behind the turbine pit.



Figure 7: Photo of the Wave Dragon reservoir part. Taken from above during initial ballasting.



Figure 8: Photo of the Wave Dragon reservoir part. Taken from below during initial ballasting.

In Figure 9 the Wave Dragon in the normal operational configuration is depicted.

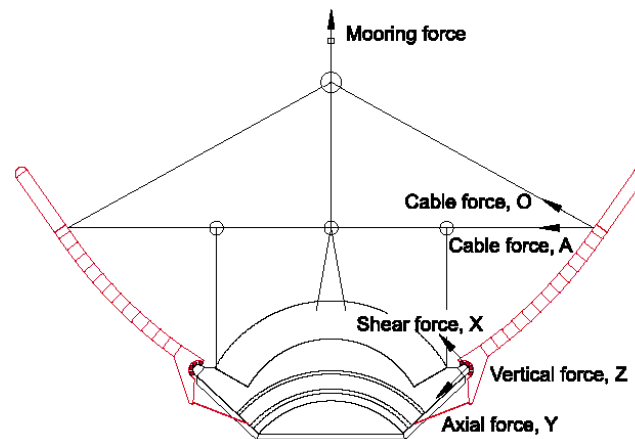

Figure 9: Normal configuration of the Wave Dragon and force registration points.

The WD is fixed in a single point to the mooring arrangement and the hydraulic behaviour depends highly on the stiffness of the mooring system. The stiffness in the central mooring line was modelling by a spring having a stiffness according to the actual design. In the mooring cables fixing the reflector arms to the reservoir body cables were pretensioned in order to keep the reflectors fixed. However, the pretensioning also determines the motions of the WD when being in operation. Maximum overtopping occur when WD is as quiescent as possible, which increases the wave induced forces, when compared to a more soft mooring system and thus larger motions. The pretensioning was decided from a maximum overtopping point of view thus disregarding the induced forces.

The hydraulic behaviour were investigated by registering forces, movement and overtopping. Each of the force registration points can be seen in Figure 9. In the cables used to tension the two reflector arms forces are registered in the across cable A, the total mooring force was measured in one single line where the structure was anchored, and finally, three force components were measured in the junction between the right reflector and the shoulder. Movements were registered for three degrees of freedom (heave, pitch and surge). Finally, also the amount of overtopping water in the reservoir was registered.

Survivability and hydraulic performance

Figure 10-14 summarizes the most important results obtained through the physical model tests. Only peak forces determined as the average of the average of the highest 1/250 of the peak forces are described in the following. This force is mainly of interest for ultimate limit design whereas the root mean square value is of interest for fatigue design. However the tendencies for the two force characteristics are the same. Results obtained with the 1. generation model (see Martinelli and Frigaard, 1999a, 1999b) are also included for comparison.

The forces in the central mooring line are in the operational sea states up to 5 MN and increases up to 10 MN in the ultimate limit sea states. When comparing the new 2. generation WD with the 1. generation forces have reduced significantly in the highest waves, and a small increase is observed for the operational sea states.

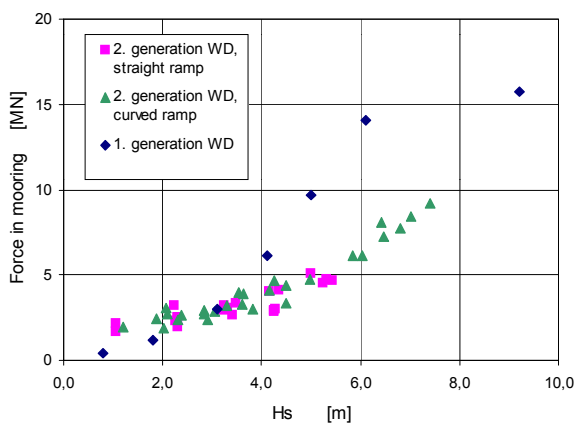

Figure 10: Mooring force for 2. generation WD.

In the mooring line termed the across cable forces are depicted in Figure 11. Again as significant reduce in force is observed which is due to the degree of pretensioning. When testing the 1. generation model the results called for less pretensioning due to the very small variations in force as the wave height increases. In the 2. generation the tensioning is

reduced by a factor 5 resulting in much more variations in forces, but without loosing the tensioning at any time. Overall forces are kept below 4 MN.

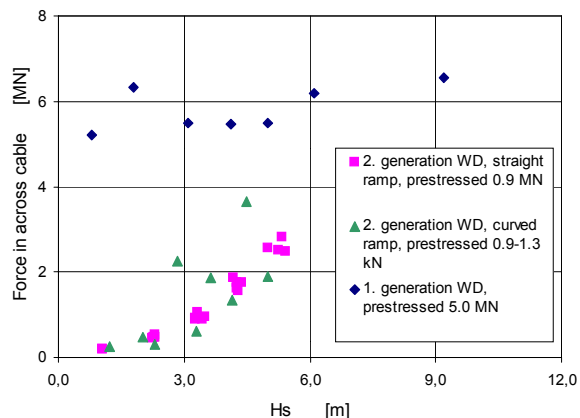

Figure 11: Force in across cable for 2. generation WD.

A key point in design is how to manage the junction between the reflector arms and the reservoir body. This structural part is exposed to severe forces as the two structural parts: the reflectors and the main body are free to move independently. The problem is sought solved by using rubber fenders fixed to the main body. The reflectors are then kept in place by two cables fixed to the rear side of the main body. The stiffness of the rubber fenders was somewhat higher than scaled accordingly to prototype fenders.

Forces induced on the main body are shown Figure 12, 13 and 14. Both positive and negative forces occur but only maximum absolute forces are plotted. The shear and the axial force are in the same order of magnitude, both forces increases slowly with wave height up to a maximum of approximately 10 MN. When comparing the 1. generation and the 2. generation model forces are comparable. The vertically induced force is on the other hand more severe with forces up to a maximum of 20 MN which is an increase by a factor 2 compared to the 1. generation model.

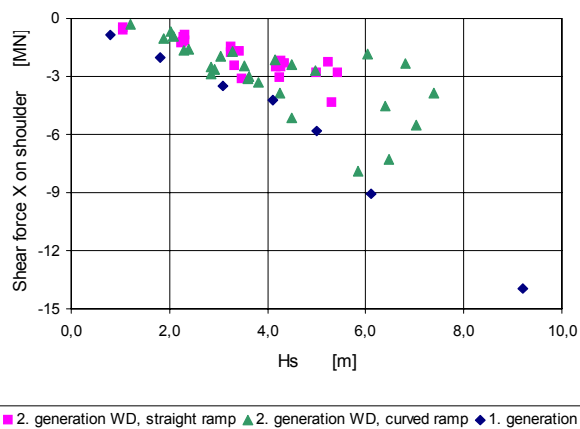

Figure 12: Shear force X on shoulder for 2. generation WD.

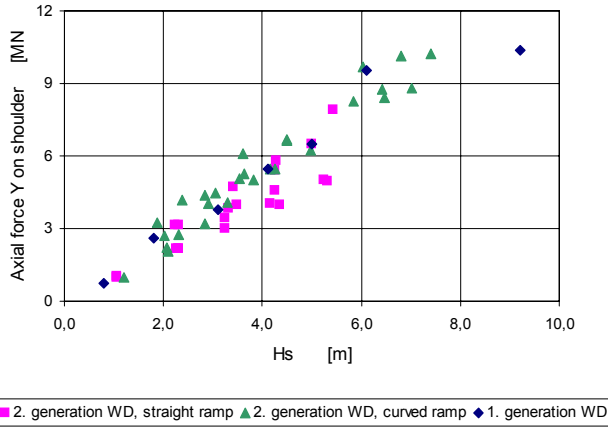

Figure 13: Axial force Y on shoulder for 2. generation WD.

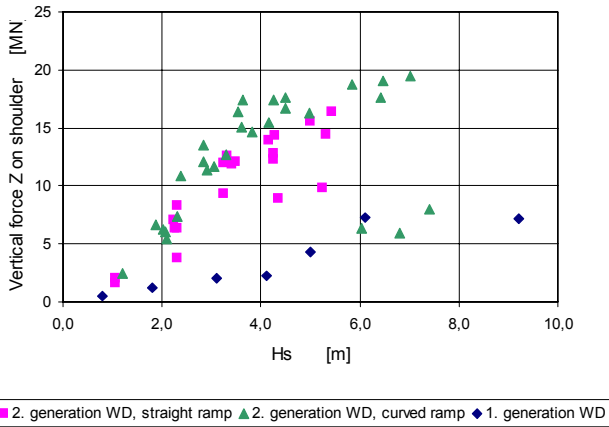

Figure 14: Vertical force Z on shoulder for 2. generation WD.

Overtopping

Overtopping was measured by collecting the water present in the reservoir into three very flexible exhaust tubes leading the water into a reservoir outside the wave basin. The water was lead into the outside reservoir by gravity from where the water was pumped back into the wave basin through an automatically controlled pump.

To control switching the pump on and off, the water level in the reservoir was registered, and when exceeding a fixed level the pump was switched on for 3 sec. To estimate the amount of overtopping water the pump was calibrated according to the water level to give certain average discharge during the 3 sec and by counting the number of switching on the total amount of water was calculated by multiplying the discharge. In consequence of this measuring technique, the model reservoir of the WD is drained during each wave. This is not the situation in the prototype where the amount of drainage depends on the turbine management strategy, i.e. to which extent the water is let through the turbines.

According to the previous tests measured values of overtopping were non-dimensionlised and presented in the following form, see Martinelli and Frigaard (1999):

$$Q^* = 0.017 \exp(-48R^*) \quad (\text{eq. 1})$$

where,

$$Q^* = \frac{q \sqrt{s_{op}/2\pi}}{\sqrt{gH_s^3 L}}$$

$$R^* = \frac{R_c}{H_s} \sqrt{\frac{s_{op}}{2\pi}}$$

q = discharge due overtopping

H_s = significant wave height

L = ramp width = 86.6 m

s_{op} = wave steepness defined as $s_{op} = H_s/L_{op}$

L_{op} = deep water wave length defined as $L_{op} = \frac{g}{2\pi} T_p^2$

T_p = peak period

R_c = Mean value of crest freeboard relative to MWL

Overtopping results obtained using the 2. generation model are shown in Figure 15 as well as the overtopping relation for the 1. generation model (Eq. 1).

Also in Figure 15 a reevaluated overtopping relation based on measurements obtained with the new doubly-curved overtopping ramp is seen. The new overtopping equation is modified to:

$$Q^* = 0.025 \exp(-40R^*) \quad (\text{eq. 2})$$

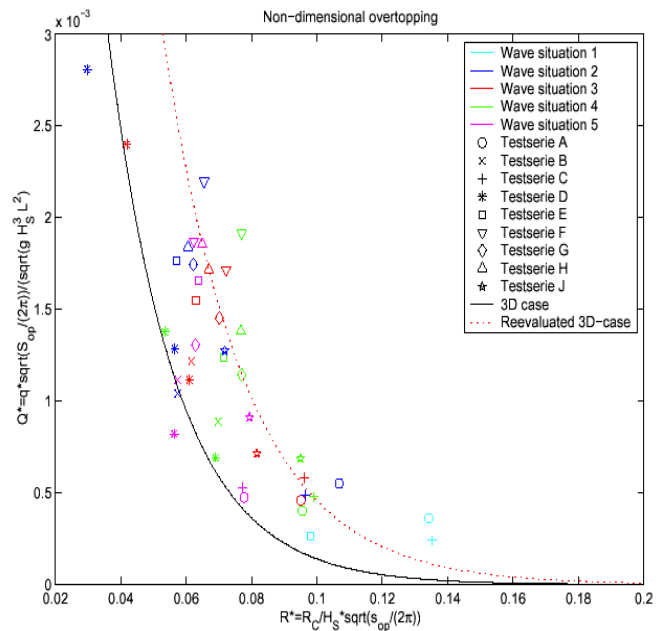

Figure 15: Dimensionless overtopping relation.

From Figure 15 is seen that overtopping is increased by approximately 100% compared to the old 1. generation model. Major parts of the increase attribute from the doubly-curved ramp.

In Kofoed (2000) the increased overtopping due to having an elliptical shaped slope instead of an optimal inclined straight slope is found to be approximately 20%. This increase was verified by 2D physical model tests with a fixed model. In the test with the floating 2. generation Wave Dragon model the increase due to the new design of the ramp was found to be even more significant.

The performed test series during the transformation of the 1. generation Wave Dragon model to the 2. generation can be seen in Table II, and in figure 16 the 1. generation parts are metallic and yellow and the new parts are painted orange.

Table II: Wave Dragon test at AAU autumn 2001 with sequentially changed parameters.

Test	Test description
A)	Stern wise expansion of reservoir, volume increased by 82% to 4764 m ³ . Construction of additional open air chambers behind centre of gravity and separation of existing air chambers from bow to stern. Extension of reflectors by 25 m. Tests conducted by +1.5 m crest freeboard.
B)	Expansion of the reflector draught by 2 m.
C)	Expansion of the reflector draught by 2 m. Tests conducted by +1.5 m crest freeboard.
D)	Trimming the bow 1 m below the stern at different wave situations: <ul style="list-style-type: none"> Wave situation 2: 2 m bow freeboard, 3 m stern freeboard (1-2)+(2-3). Wave situation 3: 3 m bow freeboard, 4 m stern freeboard (2-3)+(3-4). Wave situation 4: 3 m bow freeboard, 4 m stern freeboard (3-4)+(4-5). Wave situation 5: 4 m bow freeboard, 5 m stern freeboard (4-5).
E)	Construction of doubly-curved overtopping ramp.
F)	Construction of perforated double-walled wave damper in turbine pit.
G)	Like D with wave situation 4 changed: <ul style="list-style-type: none"> Wave situation 4: 4 m bow freeboard, 5 m stern freeboard (4-5).
H)	Construction of two guiding walls on overtopping ramp and modifying the wave damper to a perforated single-walled wave damper at the back of the turbine pit.
I)	Adding ballast (973 t). Increasing height of guiding walls by 1.5 m
J)	Fixing reflectors to the shoulders with WD located with a crest freeboard of 4 m.
K)	Combine bow and stern air chambers by tube system.*
L)	Construction pitch stabilizing air chamber above MWL at stern.*
M)	Open reflectors above pontoon near shoulders to allow for entrapped ice to escape.*

* These tests are not performed at the time of writing.



Figure 16: Original and modified Wave Dragon Geometry

CONCLUSIONS

The Wave Dragon test at AAU autumn 2001 with sequentially changed parameters and geometry of the 1. generation Wave Dragon model to establish the best possible 2. generation design has been very successful. The hydraulic performance of the design has been substantially improved, as the overtopping has been doubled. The increase in utilized overtopping is owed to the following tested structural changes:

- Increased structural width: 10%
- Less spill from a larger reservoir and improved hydrodynamic behavior primarily due to a more open bottom: 25%
- Increased draught of reflectors: 5%
- New doubly-curved overtopping ramp: 35%
- Wave damping in the reservoir and guiding walls on ramp: 5%

Compared to the 1. generation model movements and forces can be summarized as:

- Movements have decreased slightly. In the most important wave condition with respect to energy (NS 3) pitch motions have reduced 15%.
- Mooring force and forces in across cable are reduced by 50% in most extreme waves ($H_s = 7-8$ m).
- Horizontal forces in junction have reduced.
- Vertical forces in junction have increased, but test J has shown, that a minor redesign of the junction can limit these forces to 1. generation values.

The power efficiency of the Wave Dragon, which so far only can be found by computer simulations with varying numbers and sizes of turbines and different regulation strategies, has improved accordingly. The Feasibility study performed by the end of year 2000 as part of the JOULE III Wave Dragon project "Low-pressure Hydro Turbines and Control Equipment for Wave Energy Converters (Wave Dragon)", JOR3-CT98-7027 has therefore now been updated.

The main results are, that an annual power production of 10 GWh can be expected in a 24 kW/m wave climate, which can be found in the central part of the North Sea.

The conclusion of the updated feasibility study is an estimated production price of 0.11 €/kWh, while the long-term production price (2016) in a 36 kW Atlantic wave climate is expected to be as favorable as 0.04 €/kWh. This is comparable to the latest expectations to the long-term offshore wind power prices. A direct competition between WECs like the Wave Dragon and offshore wind turbines concerning deployment sites is however not to be expected, as wave energy will be competitive on sites with depths of more than est. 35 - 50 m. Here the wave power levels can be very high, and at the same time the costs of bottom standing wind turbines becomes high.

FUTURE DEVELOPMENT

In the coming years the Wave Dragon will be tested in scale 1:4.5 in Nissum Bredning, a large inlet in Denmark where the wave climate resembles the downscaled North Sea wave climate. This phase 4 of the Wave Dragon development has been secured through a grant from the Danish Energy Agency with co-funding from a number of commercial partners. The total project budget is 1.7 mill. €. Due to scale effects the rated power will be 20 kW resembling 4 MW in full scale, with the optimal number of turbines installed. From the start of the test period the Wave Dragon will however only be equipped with the existing model turbine, which can deliver 2.5 kW.

Initially the test series will focus on hydraulic behaviour and long-term testing of the turbine. The consortium is currently seeking additional funding, allowing installation of additional turbines and connection to the grid system. The scale 1:4.5 activities are expected to establish the necessary knowledge in order to deploy a full-scale offshore prototype in 2006.

The Development activities are managed in the newly established development company Wave Dragon Test ApS. Apart from the development company the consortium in the Wave Dragon scale 1:4.5 activities consist of:

- SPOK ApS, Project Management Consultancy (DK)
- Löwenmark F.R.I, Consulting Engineer (DK)
- MT Højgaard A/S, Construction Enterprise (DK)
- Aalborg University – Hydraulics & Coastal Engineering Laboratory (DK)
- Armstrong Technology Associates Ltd., Naval Architects (UK)
- VeteranKraft AB, Consulting Engineers - hydro turbine design (S)
- Balslev A/S, Consulting Engineers - electrical and automation systems (DK)

ACKNOWLEDGEMENT

The work presented is sponsored partly by the project entitled “*Low-Pressure Turbine and Control Equipment for Wave Energy Converters (Wave Dragon)*” supported by the European Union under the frame programme “Non-Nuclear Energy RTD Programme (CRAFT)” and partly by the project entitled “Wave Dragon. Reconstruction of an existing model in scale 1:50 and sequential tests of changes to the model geometry and mass distribution parameters” supported by the Danish Energy Agency under the wave energy programme.

REFERENCES

- Friis-Madsen, E., *Plant for extraction of wind/wave energy at open sea*, Danish patent no. PR 173018, Patent Classification: F03B13/22, Copenhagen, 1999.
- Friis-Madsen, E., *Offshore Wind/Wave Energy Converter*, European patent 0767876, Patent Classification: F03B13/22 – Munich, 2001.
- Hald, T., Friis-Madsen, E., *Strategy for regulating the crest free board of a floating wave energy converter*, in Proc. of the 1st International Conference on Marine Renewable Energies (MAREC), Newcastle upon Tyne, UK, 2001.
- Kofoed, J.P., *Optimization of overtopping ramps for utilization of wave energy*, Report for the Danish Energy Agency, J. No. 51191/98-0017, Hydraulics & Coastal Engineering Laboratory, Aalborg University, 2000.
- Kofoed, J.P., Frigaard, P., Sørensen, H.C. and Friis-Madsen, E., *Development of the Wave Energy Converter – Wave Dragon*, in Proc. of the 10th International Offshore and Polar Engineering Conference (ISOPE), Seattle, USA, 2000.
- Kramer, M., Frigaard, P., *Efficient Wave Energy Amplification with Wave Reflectors*, paper submitted to the 11th International Offshore and Polar Engineering Conference (ISOPE), Kitakyushu, Japan, 2002.
- Martinelli, L., Frigaard, P., *The Wave Dragon – Tests on a modified model*, Report for the Danish Energy Agency, J. No. 51191/98-0017, Hydraulics & Coastal Engineering Laboratory, Aalborg University, 1999a.
- Martinelli, L., Frigaard, P., *The Wave Dragon – 3D overtopping tests on a floating model*, Report for the Danish Energy Agency, J. No. 51191/98-0017, Hydraulics & Coastal Engineering Laboratory, Aalborg University, 1999b.
- Sørensen, H.C., Hansen, R., Friis-Madsen, E., Panhauser, W., Mackie, G., Hansen, H.H., Frigaard, P., Hald, T., Knapp, W., Keller, J., Holmén, E., Holmes, B., Thomas, G., Rasmussen, P., *“The Wave Dragon – Now Ready for Test in Real Sea”*, Proc. of the 4th international conference on Wave Energy, Aalborg University, Dec. 2000.
- Sørensen, H.C., Hansen, R., *Low-pressure Hydro Turbines and Control Equipment for Wave Energy Converters (Wave Dragon)*, JOR3-CT98-7027 Final Publishable Report, Copenhagen, 2001.